

AKG Music and Recording Applications
A Practical Hands-on
&

Ear-Oriented Guide
to Microphone Selection
in the Studio



Table of Contents

Introduction	1
The Beginnings of Hi-Fi	1
Vocal Recording.....	2
The Drum Set and Other Percussion Instruments.....	3
Micing the Marimba and Vibraphone.....	7
The Guitar.....	7
Recording the Acoustical Bass.....	9
Keyboard Instruments, Traditional and Modern.....	10
Electronic Keyboard Instruments	12
Brass Instruments	12
Woodwind Instruments	13
Recording Ensembles, An Introduction	14
Conclusions.....	18
References.....	18
Glossary	18
Summary of First-Order Cardioid Microphones	19

INTRODUCTION

Since the introduction of German and Austrian condenser microphones to the American recording and broadcast industries in the years immediately following World War II, AKG (Akustische u. Kino-Geräte) Acoustics of Vienna has been a major player. Many of our earlier condenser models were sold in the United States under the name Telefunken. Included were the ELAM 251, one of the classic tube models still sought after today for vocal recording. Shortly thereafter, AKG directly took over the U. S. distribution of all its models, and the C12 multi-pattern and C24 stereo microphones soon became legends.

Succeeding years saw the introduction of the C414 lineage and families of small diaphragm condenser microphones that are virtual staples today in recording studios around the world. For many pop-rock studio applications, dynamic microphones may have an advantage over condenser models, and AKG provides these too. Perhaps no other microphone company provides as wide an array of microphone and studio accessories as AKG.

The proper choice of microphone for any application begins with a knowledge of technical as well as musical requirements. We need to know such matters as microphone noise floor, maximum output level, and directional characteristics. Knowledge of on/off-axis response and proximity effect are important as both aspects profoundly affect musical requirements.

This Application Guide will discuss major studio usage areas in detail, outlining microphone choice, positioning, and even aspects of signal processing. We begin with a discussion of vocal pickup techniques, then move on to drums/rhythm, guitar, keyboard, and wind/brass applications.

Many terms discussed in this guide may be unfamiliar to the reader, and are listed in the glossary.

THE BEGINNINGS OF HI-FI

With the introduction of the LP in 1948 the US recording industry blazed a new trail for worldwide music. The immediate technical benefits were longer playing time and wider frequency response. Prior to that time the US recording industry had largely used ribbon and dynamic microphones, most of them made by RCA, Western Electric, Shure, and ElectroVoice. The high frequency capabilities of the LP pointed out the frequency response weaknesses of the older ribbons and dynamics, and recording engineers were quick to identify the Austro/German mics as producing the sound they wanted.

The older ribbon and dynamic microphones operated on the principle of magnetic induction. A moving conductor, actuated directly by sound, cut through a magnetic field, and an output voltage was produced. In all but a very few cases, these microphones had limited response beyond 10 kHz. The condensers on the other hand, had very light diaphragms with response well out to 20 kHz. Since they were electrically powered, they could be designed with a number of "on-board" features, including variable pickup patterns, adjustable loss pads (for picking up very loud instruments), and low-frequency rolloff for close-in vocal use.

When the "alien" Austro/German condensers were plugged into American-style consoles some interesting things happened: the extra console input gain needed for the older low-output ribbons and dynamics was too much for the condensers. The easiest way around this problem was to pad the output of the condensers, and this resulted in a net microphone impedance of about 50 ohms looking into a console input impedance of about 600 ohms.

This mismatch, in many cases, allowed the microphone to look into an undamped resonance caused by stray capacitance between the input transformer's primary and secondary windings that resulted in a response peak in the range from about 8 kHz to 12 kHz. This added a high end response rise that consumers had never heard before -- and thus Hi-Fi was invented -- at least for the record companies.

Everybody loved this new sound, and two microphone models, the AKG C12 and the Neumann U47, established new positions as studio favorites. These Austro/German mics took the high-end lead away from the American microphone manufacturers, establishing a dominance that the American manufacturers have never regained.

In the intervening years, matters of microphone output level and console input impedance have been reconciled, and today's condenser microphones routinely provide flat response under normal on-axis applications.

VOCAL RECORDING

For live on-stage applications, a handheld dynamic microphone is often the best solution for vocal recording; but in a studio setting a large diaphragm multi-pattern condenser microphone is generally the best choice. The pattern is normally set for cardioid, and typical usage is as shown in Figure 1.

Figure 1.

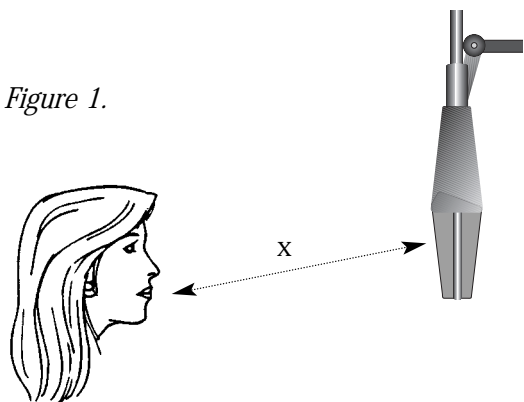

The singer may stand or sit, according to individual preference, and should be instructed to restrict head movements as much as possible. Take care not to make the performer feel musically hampered.

For close-in micing, a Nylon pop screen should be attached to the microphone to minimize the popping effects of "B" and "P" consonants on normal response. The distance (x in the figure) can be anywhere from about 0.2 meter (8 inches) to about 0.6 meter (2 feet). It may also be desirable to engage the bass rolloff switch on the microphone if the vocal quality sounds boomy.

Singers may easily reach sound pressure levels of 110 dB or higher at the microphone. While nearly all studio quality condenser microphones can handle such levels in stride, care must be taken that the console's input preamplifier does not overload. This is best done by adjusting the console input trim as needed, but in some cases it will be necessary to adjust the microphone's output pad to -10 or -20 dB ahead of the console input if the singer is especially loud.

Proximity effect is a property of all directional microphones, and it tends to produce elevated bass response as the sound source moves closer to the microphone. A typical example of proximity effect with a cardioid pattern microphone is shown in Figure 2.

Figure 2.

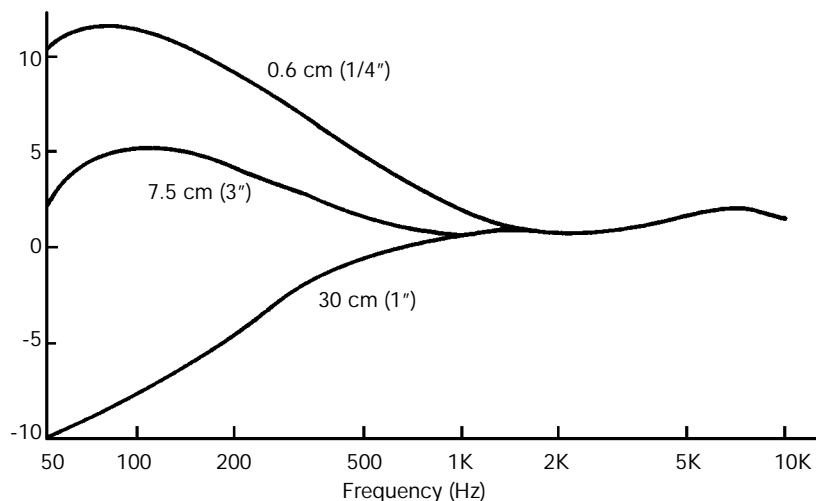

In studio work, proximity effect functions to some degree as an equalizer since it is fairly easy to control. This creates an automatic bass boost that flatters most voices.

The choice of a large (25 mm) diameter capsule over a small (12 mm) one is not necessarily a "scientific" one. It has been observed that most studio multiple-pattern large diaphragm models exhibit a broad rise in the 8 to 12 kHz range that flatters most vocalists. There is further expectation on the part of many artists that a large microphone is somehow better than a small one, perhaps due to the record album covers over the decades that show famous pop singers using them. It is better to leave certain myths alone.

From a purely technical viewpoint, the differences between well designed half-inch and one-inch microphones is minimal. All else being equal, the larger diaphragm microphone can be designed with a lower self noise level than the smaller one; but as an example of the design trade-offs involved, the smaller microphone will exhibit better off-axis high frequency response than the larger one.

What to Listen For

While vocal tracks are always processed during postproduction, little can be done with a track that has not been recorded correctly. If the voice sounds too bright or too boomy, then change microphones or microphone position. Any sign of overload should be corrected immediately through careful determination of console gain structure.

If your console is of the in-line type, you can set up the monitor mix using any anticipated dynamic range compression, EQ, de-essing, and reverberation that you and the producer think will be used during the final mix. However, leave the original track (or tracks) absolutely dry and sweeten the monitor mix only after you are certain that you have chosen the appropriate microphone.

Be careful not to record a vocalist so closely that normal variations in the artist's front-back positioning creates large apparent differences in volume level or in the degree of proximity effect. Carelessness here will result in trouble during the mix.

Be aware that many vocalists have strong ideas regarding how they should be recorded – and with what microphones. Avoid confrontation with an artist over this point, and remember that the artist might be right. Whenever possible, listen to previous recordings by the artist so that you have a reasonable frame of reference for any suggestions you wish to make. Do not play for an artist other recordings you have made in order to prove a point unless the artist suggests that you do so.

Summary of AKG microphones for studio vocal use:

C12VR A modern reissue of the original tube-type design. Recreates the sound of the fifties and sixties and is probably the best choice for pop work, where the high frequency rise is useful. Handles very high levels in stride.

C414B/TLII The transformerless version of the C414 works well for vocals because of its ability to sustain very high acoustical levels. Uses the same diaphragm assembly as in the C12VR.

SOLIDTUBE This new large diaphragm tube condenser has a single pickup pattern (cardioid), and is intended primarily as a studio model for vocal or instrumental solos.

C4000B Excellent dynamic range and low self noise. Selectable polar patterns allow flexibility on stage or in the studio.

C3000B Its large diaphragm provides a wide dynamic range and exhibits a mild high frequency rise.

C2000B A small diaphragm mic with extraordinary high sensitivity and low self noise.

C1000S AKG's most versatile mic. Two polar patterns - high frequency emphasis - on/off switch.

Please experiment! No single microphone can handle all studio vocal requirements. Take the time to try several models before settling on one.



C12VR



C414B/TLII



SOLIDTUBE



C4000B



C3000B



C2000B



C1000S

THE DRUM SET AND OTHER PERCUSSION INSTRUMENTS

Many philosophies apply to micing the drum set. In jazz, it may be sufficient only to have an overhead stereo pair with a third microphone on the kick drum. In rock recording, more than ten microphones may be used as most musical decisions are reserved for the mixdown session.

The drum set is normally composed of the following elements:

Kick drum (played by the right foot)

Snare drum (played with sticks or metal brushes)

Hi-hat cymbals (normally struck with a stick, while the left foot is used to raise and lower the upper cymbal)

Various cymbals (suspended at the middle and normally struck with a stick; three are typically used)

Set of tom-toms (normally three of these, tuned low, mid, and high; played with sticks)

Some players vary this array slightly, with more or less cymbals and tom-toms than the quantities stated here. Figure 3a shows a frontal drawing of a typical drum set. In this figure we show the main overhead microphone pair and a single microphone on the kick drum.

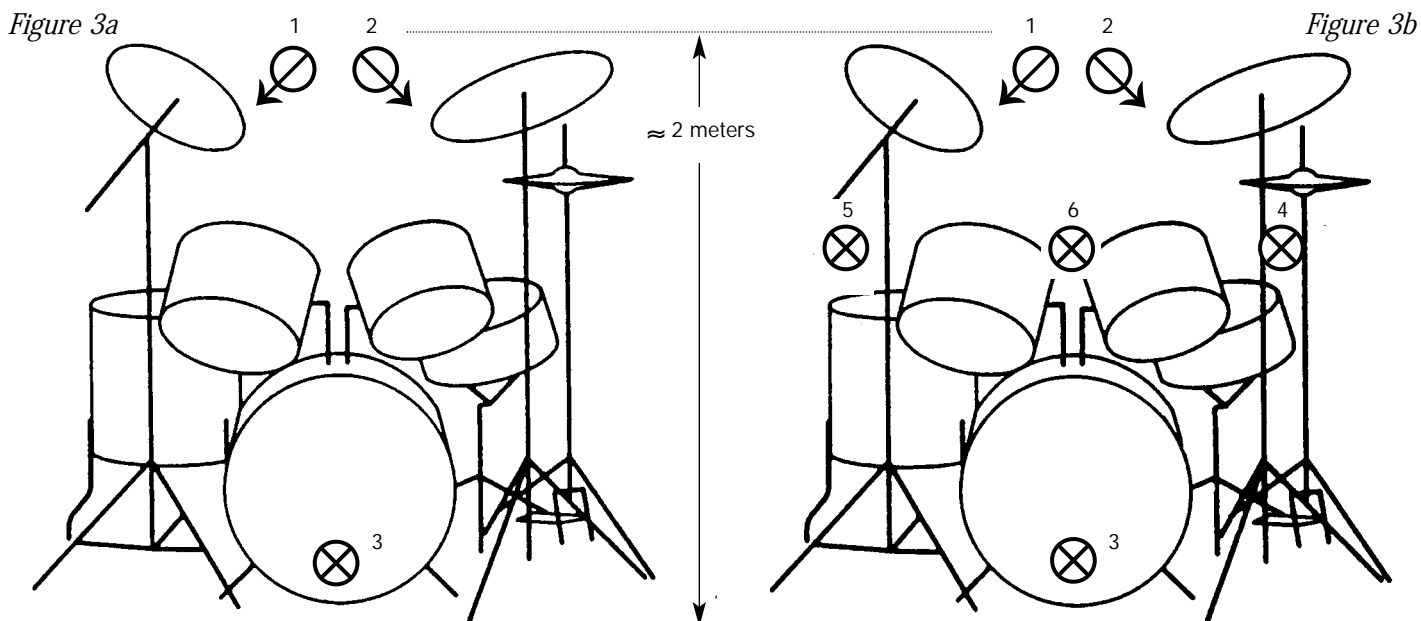

While there is no standard way of micing the drum set, a typical approach might be as follows:

1. Stereo Overhead Pair

Use a small diameter condenser cardioid that has a flat on-axis response, such as the C480 preamplifier with the CK61 capsule, pointing them downward. The small diameter capsules will ensure good pickup as their acceptance angle remains quite wide at high frequencies.

This can be via a spaced pair of cardioids, or perhaps an X-Y pair. (X-Y indicates a coincident pair, splayed up to 120°.) The height above the drum set is normally about 0.4 to 0.5 meter (16 to 20 inches) above the head of the performer. If spaced cardioids are used, they should be separated laterally by 0.6 - 0.8 meter (2 to 3 feet).

The C426 stereo microphone may be used here as well. An alternate approach is to use a stereo microphone in which the cardioid patterns have been splayed between 90° and 120°. The stereo microphone should be placed just forward of the player's head to avoid any shadowing. The center of the splay angle should point directly downward.

What to Listen For

The overhead pair of mics should have a nicely balanced sound with no trace of peakiness. They will favor the cymbals somewhat because of their placement. Listen for stereo imaging to determine if this is a problem. Pan the two microphones hard left and right. The spaced pair will sound relatively spacious, while the coincident pair, (or stereo microphone) will have tighter, more specific imaging.

Next, pan the two microphones to a smaller listening angle. As a starting point, pan the left microphone to the left loudspeaker and the right microphone to the center of the stereo array. Now listen again. As often happens, the coincident pair will sound a little too "mono," while the spaced pair will convey a good stereo spread. Use your judgment to assign the overhead microphones to a pair of tracks and record them absolutely dry.

2. Recording the Kick Drum

There are several kinds and sizes of kick drums. Those used in acoustic jazz often have a head on the playing side only, and as such, they can be tuned to give a fairly low fundamental frequency. It is customary to place a cardioid microphone either on the player's side of the head, or on the far side with the microphone placed slightly inside the rim of the drum. Arguments of signal polarity aside, there is normally little difference in the two placements. The argument comes in the choice of microphone type, dynamic or condenser. Sound pressure levels near the drum head can be quite high. Some earlier condenser microphones may not have been able to handle these levels and were replaced by some of the hardier dynamic models. Remember that dynamic microphones go into distortion fairly gently, while condensers, because of their internal amplification circuitry, tend to go into distortion rather abruptly. This is likely the difference that has given rise to the preference on the part of many recording engineers for micing the kick drum with a dynamic. Since it is difficult to find a dynamic cardioid with a truly extended low end, we recommend using a condenser cardioid that has adequate overload margin. In some cases it may be necessary to switch in the microphone pad in order to gain adequate headroom.

What to Listen For

Monitor the kick drum by itself for a few moments. Because the microphone is virtually inside the kick drum, there will be a good bit of truly low frequency signal due to proximity effect (make sure that the internal LF rolloff switch on the microphone is in the off position.) Make sure that the loudest kicks the player will make come through cleanly. At any point where it seems appropriate, ask the drummer to come into the control room and listen to a recorded segment of this (or any other) example of experimental micing that you are currently working on. In most pop or jazz recorded textures, the kick drum should be the lowest frequency signal present, but not necessarily the loudest. If there is a need, the player may tune the drum down a slight amount to get the sound you are looking for. There is a limit to this procedure, however. Trust the drummer.

3. Close Micing within the Drum Set

In jazz recording there is generally the expectation that the sound of the drum set must not be too different in overall balance from what you might hear in an intimate jazz club. Figure 3b (on the previous page) shows typical microphone locations for spot micing the drum set. On many occasions, engineers will place spot microphones on the high-hat cymbals. In general, we recommend small diaphragm condenser cardioids for all these applications, making absolutely sure that the microphones are on the far side of the instruments as seen by the player. Make sure that the microphones are a few centimeters (an inch or so) away from the instruments so as to avoid any contact with them. The cymbals are probably least in need of spot micing because of their positions close to the overhead microphone pair. However, a producer or performer may wish for more presence. It is more likely that the tom-toms may require spot micing, especially in those productions where drums are featured. Follow the same general guidelines as before.

Managing the Microphone Array

It is easy to see how micing the drum set can quickly get very complicated. It seems that there are never enough available tracks to store everything individually. While it is imperative that the main overhead pair and kick drum be assigned to three tracks, the large number of possible spot microphones will have to be subgrouped in some useful way. Here are some options:

- a. Group all internal spot microphones into a stereo subset, with all panning assignments carefully made. This approach requires only a pair of extra channels, but calls for careful management of individual microphone gains during monitor-mix recording operations. Make sure the levels of these signals are high enough to ensure a good dynamic range in later postproduction operations.
- b. If you have the tracks available, you may want two or more stereo pairs for the spot microphones. These give added flexibility for later remixing.
- c. In truly complex material, the drummer may wish to build up a final mix through overdubbing in several passes. Each pass should be done in stereo, and the multiple stereo recordings would be combined later, or perhaps discarded and replaced.

What to Listen For

Spot microphones are generally intended to be used very sparingly in the final mix and the only gauge the engineer will have during the tracking process is what is heard over the monitor mix. Remember that we are recording a drum set, and it should sound close, but completely natural. Be very careful with all panning assignments of spot microphones; place them in the stereo image (or stereo sound stage) where they appear physically in the drum set.

4. Additional Percussion Instruments:

Additional percussion instruments may require one or more players, depending on the complexity of the orchestration. For the most part we encounter additional instruments of Latin and African origin: some of these are:

Gourds The guiro is a hollow gourd with serrations that are scraped with small metal bars. Maracas are gourds filled with seeds; they are shaken, causing the seeds to vibrate.

Drum related The tambourine is a small hoop with a drum head on one side that is struck or rubbed with the thumb. Small metal "jingles" are located in the rim and vibrate against each other when the instrument is shaken. Bongo and conga drums have a head on one side. They are tuned and are played with the fingers.

Wood Against Wood The claves are a pair of dense wood sticks that are struck against each other.

Metal Against Metal The cocolo (may be known by other names) has metal beads that can rotate around a grooved metal cylinder as the instrument is turned back and forth in one hand.

Tuned Wood and Metal Bars, the Marimba and Vibraphone Played with mallets of various hardness, with up to two held in each of the player's hands.

To a greater or lesser extent these instruments show up in jazz and popular recordings. With the exception of the marimba, vibraphone, and bongo drums, a single player may play several of these instruments at different times. Most likely, two or three players can handle all of the smaller percussion instruments, which makes it relatively easy to record them in stereo.

Do not record these instruments too closely. With their transient nature they will cut through even the densest textures with no problems. In most cases, a single coincident or spaced stereo microphone pair will do the job very well.

What to Listen For

When recording the smaller percussions the engineer should listen for naturalness as well as a rich and well-spaced array of images on the stereo stage. When possible, assign the percussion instruments to stereo pairs of tracks. The larger instruments (marimba, vibraphone, and arrays of bongos) should each be picked up with a stereo pair of microphones. The usual arraying is high to low spaced from left to right. Record all percussion instruments dry for maximum postproduction flexibility later.

Summary of AKG Microphones for Percussion Recording:

Overhead Drum Set Small diaphragm condenser mics such as the C480/CK61 combo, C1000S, C2000B and the C391B are considered standard. However, you may also try large diaphragm models, such as the C414B/ULS, C426 stereo or C3000B.

Kick Drum The C414B/ULS is excellent here for its ability to handle levels as high as 145 dB. Also, experiment with some of the contoured dynamics, such as the D112, a good choice because of its very high overload capacity.

Close Micing in the Drum Set The C2000B, C391 and C480 series are recommended for their very accurate response and ability to handle high sound pressure levels. The C418, D440 and D550 are well suited for situations where space is limited. Each model can be attached directly to a tom or snare drum, eliminating the need for mic stands.



MICING THE MARIMBA AND VIBRAPHONE

Both of these instruments should be miced in stereo, about 0.5 meter (20 inches) overhead, slightly in front of the instrument to avoid interference with the player. Listen for good stereo spread, and if the instruments seem too dominant, to reduce the bass slightly, using the in-line equalizers in the console.

THE GUITAR

The guitar is an essential instrument in jazz and pop recording. In rock recording it is of utmost importance as it carries the bulk of the harmonic structure and the bass line.

From the acoustical viewpoint there are two kinds of guitars: the traditional acoustic (hollow body) type and the modern solid body type. The acoustic guitar was the original form of the instrument. Although it can produce a moderate acoustical output on its own, it is customary to fit the instrument with an electrical pickup so that it can be easily amplified. In jazz and pop work it is customary to mic the body of the instrument itself, and perhaps combine the direct output from the pickup element.

By comparison, the solid body guitar has no resonance to provide acoustical output. Only the strings resonate, and they are always amplified through direct pickups mounted on the body, followed by further signal processing before final amplification. In recording, the solid body guitar may be picked up two ways. The output of the electrical pickup can be fed directly into the console, and the acoustical output of the associated guitar amp/loudspeaker combination can be picked up with a microphone.

The so-called electric bass, or bass guitar, is a standard size solid body guitar with four strings tuned the same as the large acoustical double bass, or bass viola. The electric bass has virtually taken the place of the acoustic bass; however, it is not unusual to find acoustic and solid body bass guitars intermixed.

Figure 4a shows the top view of an acoustical guitar with several micing options. The X-Y pair will give a strongly centered stereo image, while the A-B pair will give an added degree of stereo spread with less image specificity. Combining the two micing approaches is not recommended; it complicates the recording process for the slight increase in flexibility it offers.

Figure 4

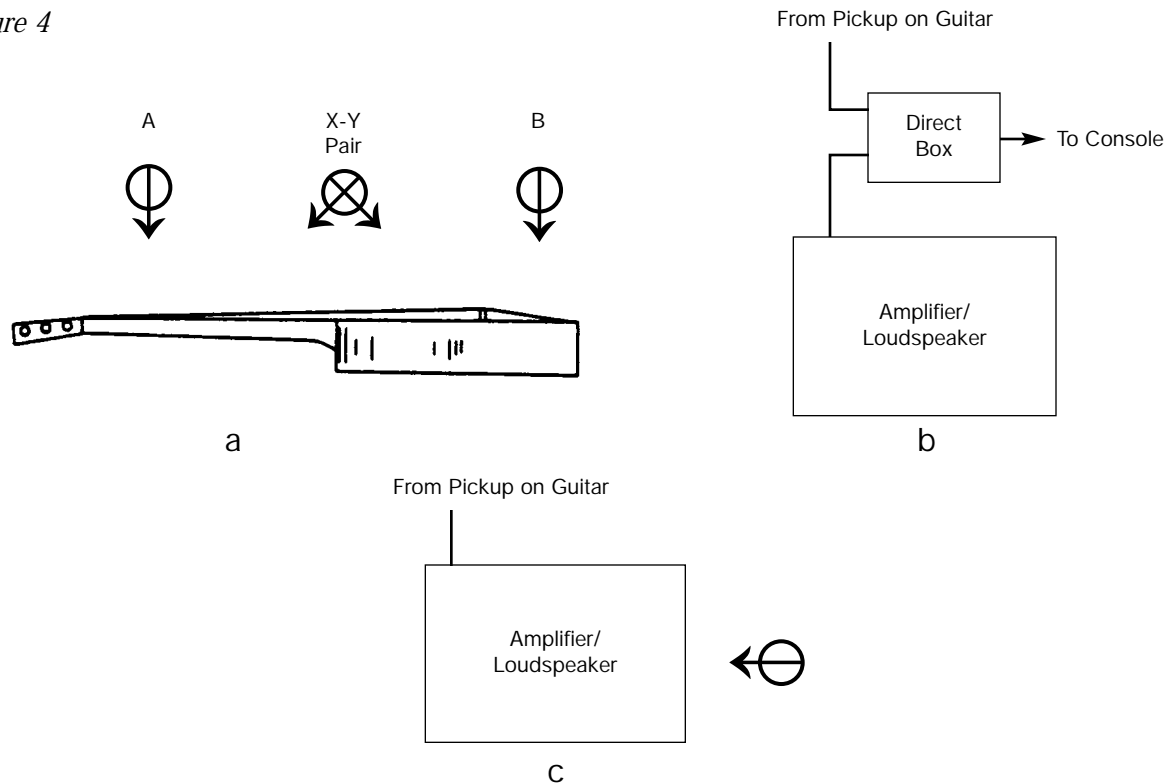

What can be combined are the stereo microphone outputs with a direct output from the guitar's pickup, or from the direct output of the amplifier, as shown in Figure 4b and 4c. This may be panned into the center for a more solid image. Alternatively, some engineers prefer to use a microphone for one of the stereo channels and the output of the amplifier for the other stereo channel.

What to Listen For

A stereo guitar track that you are laying down in the studio may be equalized and processed later in postproduction. Do not be concerned with proximity effect at this point. These tracks can easily be EQ'd as needed later. Get as natural a high end as you can. Some players and instruments are quite "mellow" sounding, and large diameter cardioids may brighten things up a bit. Otherwise, small diameter condenser cardioids will generally work better.

Some players produce a good bit of finger noise on the strings. If this is a problem, use more of the direct feed from the instrument, since this will minimize the effect.

Summary of AKG Models for Recording the Guitar

C414 models Gives slightly bright, but not peaked, sound quality; useful if the basic guitar sound is on the mellow side.

C480 series Gives flat and extended high end; best used if the instrument tends to the bright side.

C2000B 1/2" transducer provides accurate high frequency detail and a smooth rolloff to compensate for close mic'ing bass boost.

C1000S Multiple mic'ing options available. switchable polar patterns and high frequency emphasis when using the provided accessories. PB1000 (presence booster) can really brighten up nylon or otherwise "dull" sounding strings.



RECORDING THE ACOUSTICAL BASS

The acoustical bass, double bass or simply bass, as it is generally known, may be picked up a variety of ways. These include direct pickup; by electrical feed from the bass amplifier; by micing the loudspeaker directly; and finally by placing a microphone adjacent to the instrument, as shown in Figure 5a. Other pickup options are shown in figures 5b and 5c. The microphone should be about 20 to 24 cm (8 to 10 in) from the strings, and the height should be adjusted in the range between the bridge and the playing portion of the strings. This will allow for the correct balance between the actual note itself and the sound of the action of the fingers on the strings as the bass is almost always played *pizzicato*, or plucked.

Figure 5

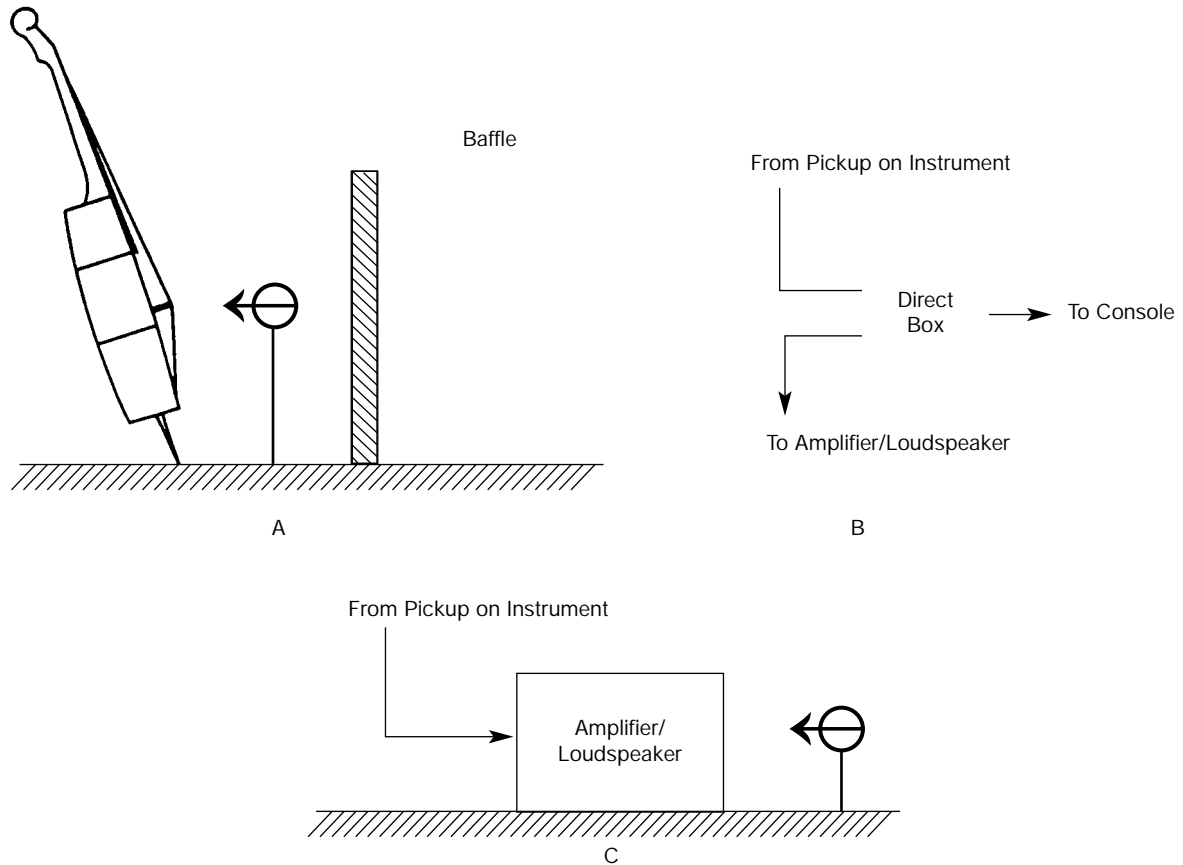

A cardioid pattern is most often used. It may be necessary to roll off some low end in the console because of proximity effect. Either a condenser or dynamic will work, depending on the desired sound.

Some engineers prefer to place a small condenser in the space between the tailpiece and the bottom of the instrument. This ensures that any movement of the instrument will not affect either the level or amount of proximity effect. We suggest experimenting with an omnidirectional microphone if this option is chosen. A baffle may have to be placed just behind the microphone in order to keep down leakage from louder instruments in the studio.

What to Listen For

Getting the bass line correctly is the foundation of much pop/rock and jazz recording, so be prepared to take some time to find just the right sound, especially if you are working with a new artist or group. Try to get the bassist into the studio as early as possible to work on a number of options.

In traditional jazz, a natural sound, with lots of finger sounds, is often wanted, while in blues music less of this is usually the rule. Experiment by recording both miced and direct pickup of the instrument, balancing them against each other in postproduction.

Summary of AKG Models for Recording the Bass

C414 series Always a good choice for timbre (sound quality) and for absolutely clean sound. Experiment with the various polar patterns.

C480 series The CK62 omni directional capsule is a good choice for micing in between the tailpiece and instrument body. Experiment with various patterns.

D112 This microphone is ideal for the applications discussed previously. Its presence peak at 4 kHz will enhance upper harmonics and finger action on the strings.



C414B/ULS



C480



D112

KEYBOARD INSTRUMENTS, TRADITIONAL AND MODERN

The instruments to be discussed include the traditional piano, celesta, and harpsichord. The modern keyboard-based synthesizers, electric pianos, and electronic organs will also be discussed in this section.

The piano has never been an easy instrument to record. Many problems arise from the quality and maintenance of the instrument itself. No amount of fine microphones and recording art and technology can compensate for a poor instrument. In a studio setting, nothing less than a 7-foot (Steinway model B or equivalent) should be considered. Only an instrument that is freshly tuned and in good regulation should be used in any serious recording application.

It is surprising to many that the piano is normally recorded at close quarters, especially in the pop and rock studio. The approaches shown in Figure 6 are typical. The microphones are placed well within the instrument, and two are normally used in a high-low combination that is useful for stereo presentation. Several possible positions are shown. Experiment as often as you can. Some engineers prefer to use boundary layer microphones for this application, with the piano cover fully down.

Many engineers will place the two microphones even closer to the sounding board, and may set the piano cover in its lower position (so-called "half-stick"). This may often be done as a measure to keep down leakage into the piano microphones from louder instruments in the studio.

Figure 6

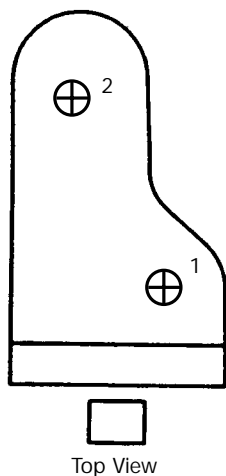

Top View

Note: Pan 1 left of center and 2 right of center for normal stereo perspective

Both microphones about 0.3 m above strings.

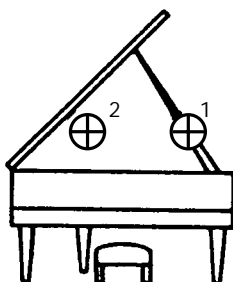

Front View

Since all of these microphone positions will pick up only direct sound from the instrument, some degree of artificial reverberation will be necessary in postproduction. Typically, the microphone covering the higher strings will be assigned to the left channel and the microphone covering the lower strings to the right channel in the final stereo mix.

What to Listen For

How close you should get to a piano in the studio depends on the tastes and desires of the producer. A hard, brittle sound may in fact be very appropriate for certain kinds of music. In general, go for a fairly full bottom end, which happens normally if you use cardioids. Listen for any traces of distortion; engage the microphone's pad if you hear any. Record dry and add reverb later.

Solo Piano

A solo piano may be recorded in a more natural ambience as shown in Figure 7. The choice is normally between a spaced omnidirectional pair or a coincident cardioid pair. The coincident pair will give a tighter image, if this is desired. The spaced omnidirectional pair should be experimented with carefully, taking care that the microphone spacing does not exceed about one yard. The technique can yield a beautifully spacious sound which retains good stereo center image fill at lower frequencies.

Figure 7

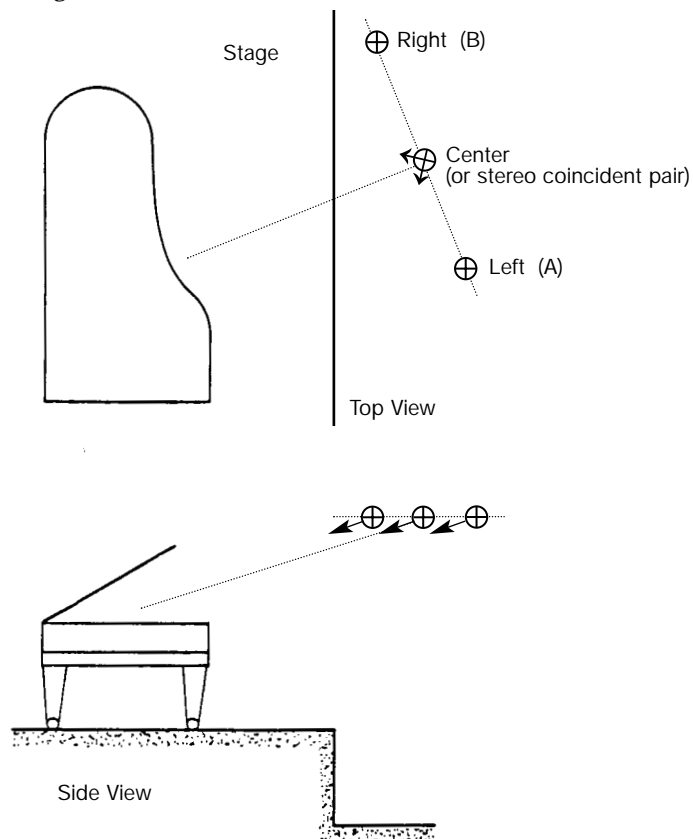

Summary of AKG Models for Recording the Piano:

C414 models These are favorites because of their ability to stand up to high levels and their variety of pickup patterns.

C12VR The warmth of tube microphones matches well with their ability to handle very high levels.

C562BL For those times when you want to use boundary layer microphones, tack onto the inner surface of the piano cover. You may want to experiment with three (low, mid, and high) for coverage of the full range of the instrument.



C414B/TLII



C12VR



C562BL

ELECTRONIC KEYBOARD INSTRUMENTS

For the most part, these instruments are fed direct-in to the console from stereo outputs. There is one very famous exception, the Leslie loudspeaker that is invariably used with Hammond electronic organs. The Leslie is a two-way loudspeaker system with rotating elements that phase and frequency modulate the sound output. The traditional method of stereo micing the Leslie is shown in Figure 8. One or more microphones may be placed at the top of the Leslie enclosure to pick up high frequencies, and the other is placed close to the floor to pick up low frequencies. There is normally enough leakage between these two pickups to ensure a good stereo image. Any cardioid condenser will work here, and the distance from microphones to the enclosure may be as small as 10 cm (4 inches). Also, the D112E works well on the lower (bass) element.

BRASS INSTRUMENTS

Brass instruments are relatively straightforward, inasmuch as radiation from them is entirely by way of the bell. Figure 9 shows several brass instruments and suggested studio micing. Be aware that brass instruments can be played quite loudly, so distortion may become a problem later. Also, the trumpet and trombone can both develop considerable high frequency content at high playing levels and when playing with certain kinds of mutes. This is a good argument for using as smooth a microphone as you can find, as well as keeping a close eye on console input levels.

Many engineers trained by, or apprenticed to, older engineers who grew up in the early 1950's will actually use the old RCA ribbons for close-in placement to brass instruments. The ribbons are usually somewhat rolled off at high frequencies, which creates a desirable antidote to the excessive high frequency output of the instruments. Another factor in favor of the old ribbons is their relatively low output, which means that they will not overload the console input. Today, most engineers prefer smooth condensers, but are ready to engage pads when necessary.

Figure 8

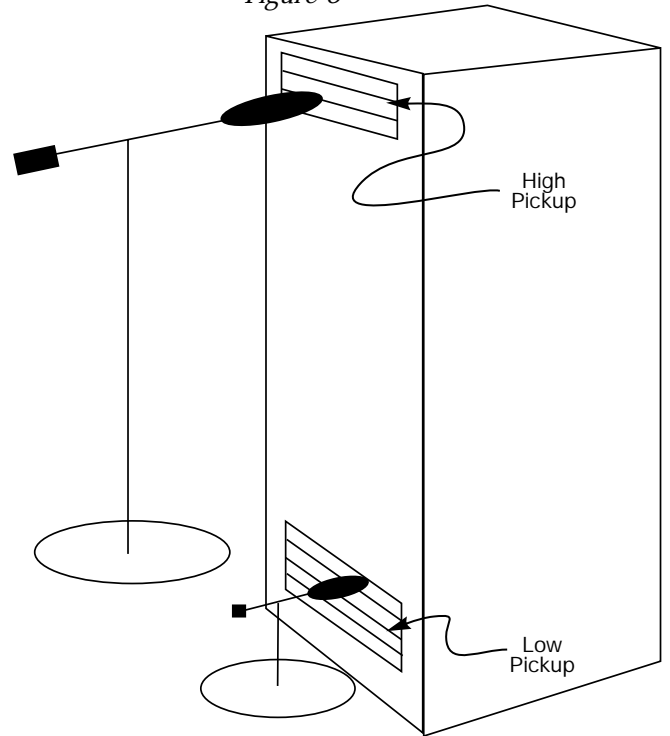
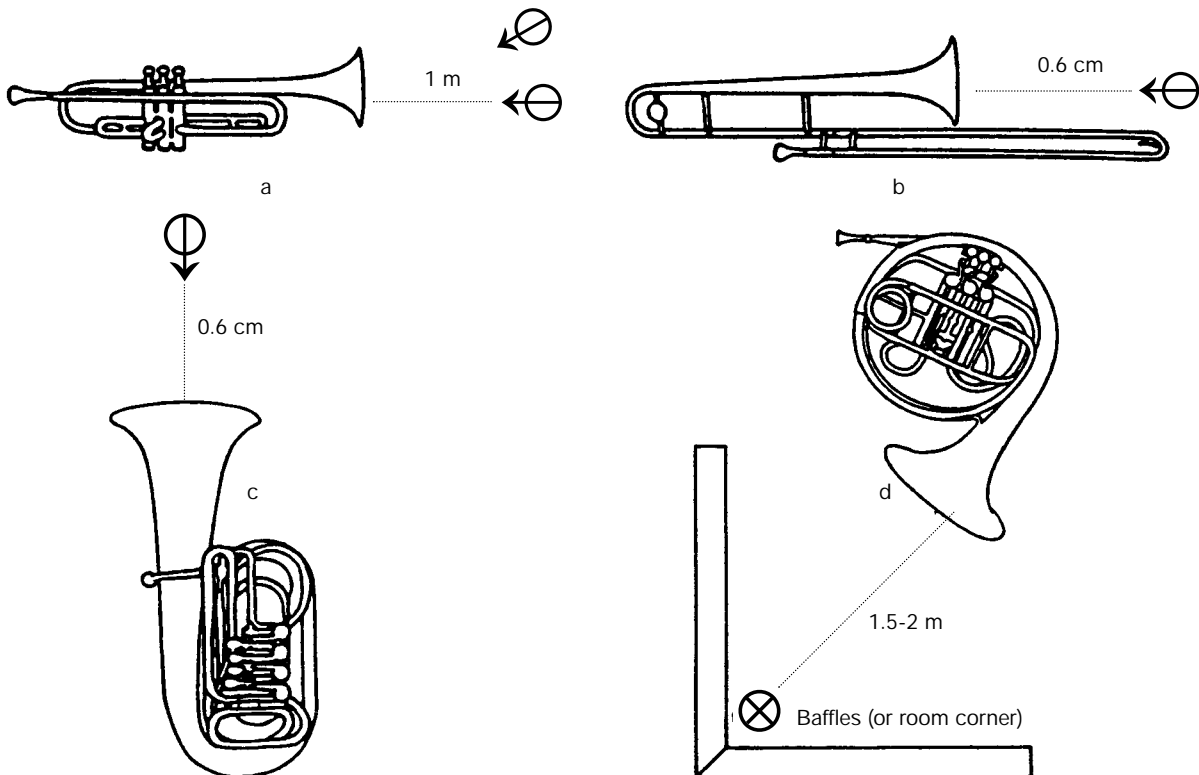

Figure 9



What to Listen For

Do not hesitate to move microphones a bit farther away from the instruments than shown in Figure 9 if it will create a better sound and does not give you leakage problems. You may also place the microphone slightly off-axis to diminish the high end. Many veteran brass players slightly favor the old ribbons and will suggest them when they hear a sound that is too bright. A slight amount of EQ rolloff in the console may help a bit.

Summary of AKG Models for Recording Brass:

C414 Series Just about every studio engineer's favorite microphone for brass, due to its ability to handle very high sound pressures.

C12VR Another favorite noted for its tube-type warmth and brilliant high frequency.

SOLIDTUBE AKG's new tube, large diaphragm studio cardioid microphone with subtler highs than the C12VR.

C4000B Extremely large dynamic range and low self noise. Works well in high sound pressure environments.

WOODWIND INSTRUMENTS

The woodwinds as a family have very complex radiation patterns. Only when all the keys are down is the radiation directly from the bell of the instrument. Under all other playing conditions, the radiation is by way of the open key holes and the bell. Figure 10 shows a basic summary of the microphone positions that give smooth pickup over the entire frequency range of the various instruments.

For the straight reed instruments (clarinet, oboe, English horn), the best microphone position is about one-third the distance from the bell to the mouthpiece, placed about the same distance out from the instrument, as shown in Figure 10a. The flute does not have a reed, so radiation is from the mouthpiece as well as from the open key holes. The position shown in Figure 10b favors the lower portion of the instrument slightly, but is recommended because it diminishes some of the "breathiness" of the instrument. The saxophone, because of its S-shape, allows a placement along the bell that is also at the requisite position from the keyholes, as shown in Figure 10c.

Figure 10

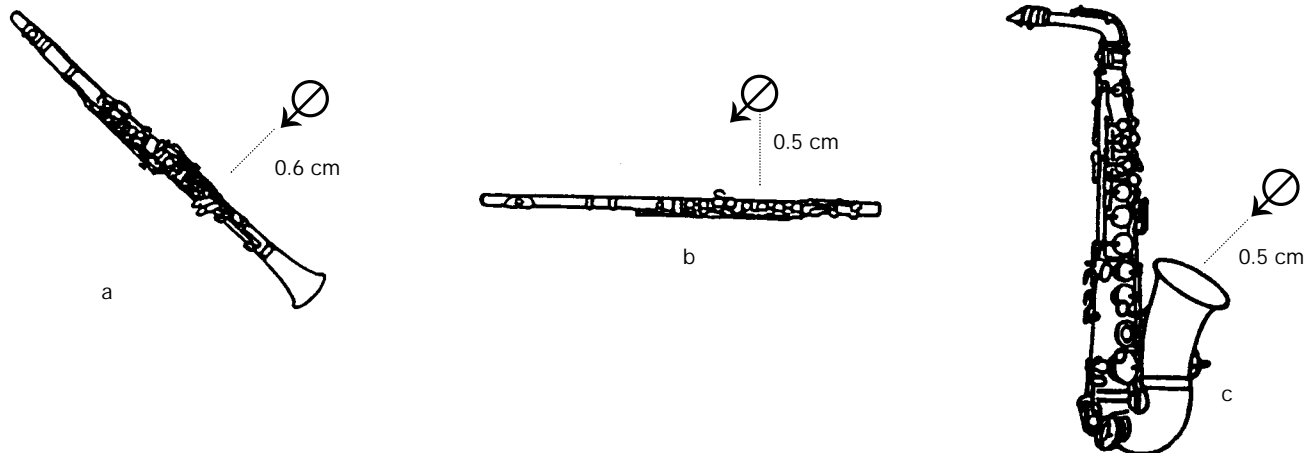

C414B/ULS

C12VR



SOLIDTUBE

C4000B

The practice of mounting clip-on microphones on the bells of woodwind instruments presents real problems in spectral balance, but it is common nonetheless. A clip-on microphone on the bell of a saxophone might not be too far off target, due to the proximity of the key holes.

What to Listen For

What you are generally looking for with these instruments is a neutral, thoroughly realistic timbre, or quality of sound. Generally, a modicum of proximity effect is beneficial. The keying system on many instruments can be slightly noisy, especially if the player manipulates the keys rapidly, with a strong motion. Most players, if they can hear the problem over the monitors, will be happy to let up somewhat to solve the problem. Often, you will have to move the microphone slightly away from the player to alleviate the problem.

Summary of AKG Models for Recording Woodwinds

C480B, C2000B and C391B These small diaphragm microphones have very uniform response both on- and off-axis. Since the pickup involves sound arriving from several directions, the response uniformity will be better than using a large diaphragm microphone.



RECORDING ENSEMBLES, AN INTRODUCTION

The recommendations given thus far in this manual have applied primarily to those studio applications where utmost isolation between tracks is essential. Thus, the micing procedures emphasize close placement, with the stereo finished product created by channel assignment and panning during the mixdown operation.

In recording large ensembles, each microphone in a stereo pickup array "hears" many instruments, and the positioning of a given instrument in stereo playback is primarily dependent on where it is located in the ensemble, both left to right and front to back.

The techniques we will discuss in this section are a part of normal classical recording practice for orchestras. There are applications in studio recording, such as a vocal chorus of twelve or more. String ensembles are also integrated into pop mixes, usually via overdubbing, or "sweetening" at a later time.

There are several fundamental approaches to getting a good stereo sound stage:

1. Crossed Figure-Eights

Figure 11 shows two figure-8 microphones placed one on top of the other and rotated so that there is a 90° angle between them. One microphone is panned left and the other one to the right. This stereo microphone array, often known as the Blumlein technique, will create a very natural sounding stereo soundstage. Source 1 is located at the left and lies along the major axis of the left microphone. Source 1 also lies in the null, or zero output zone of the right microphone and will not be picked up by that microphone. Thus, source 1 will be heard in the left channel only. Reflected room sound from source 1 will enter both microphones.

Source 2 lies along the region of equal overlap of the two microphone patterns and will be picked up equally by both figure-8 microphones. Source 2 will appear in the center of the stereo soundstage. Source 3 is the mirror image of source 1 and will appear at the right side of the stereo soundstage.

More to the point of good stereo pickup, sources located at positions between sources 1, 2, and 3 will be localized accordingly. Front-to-back relationships will be maintained as well; the ratio of direct to reflected sound will create for the listener a relative front-to-back impression in the reproduced soundstage.

Figure 11

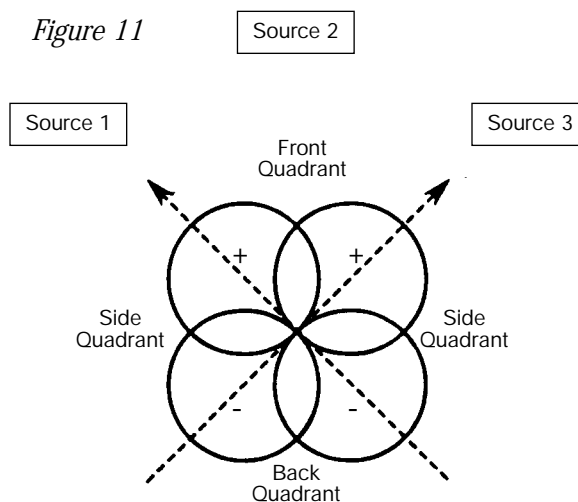

The Blumlein technique works very well in moderate live recording spaces and can be used to pick up choral groups and small orchestral ensembles. For best effect, the performers must be within the front quadrant of the microphone array. The side and back quadrants will pick up reflected room sound and reverberation.

What to Listen For

Since the Blumlein array is effectively "open" in all directions, care must be taken to position the performers so the desired ratio of direct-to-reflected sound is correct before recording begins. It is best to err on the close side, since artificial reverberation can be added in postproduction. Do not hesitate to have players or singers move to other positions if necessary. Keep the array of performers as wide as possible within the front quadrant.

Summary of AKG Models for Blumlein Stereo Recording:

C426 This AKG model is one of only a handful of correctly engineered stereo microphones available. It contains two variable pattern cartridges stacked vertically that can be rotated relative to each other. The pickup patterns are remotely controlled.



C414B/ULS

C426B

A pair of C414 microphones may be used in their figure-8 patterns, closely spaced and rotated 90°. The rigging here is fairly complicated and should be used only when there is no stereo microphone available.

2. Crossed Cardioids:

Figure 12 shows the use of crossed cardioids and hypercardioids. As with the Blumlein array, the best technique is to use the C426 stereo microphone. These two approaches to coincident stereo recording are handy in the studio for picking up small groups, with good isolation from other players in the studio.

Figure 12

A note of caution: because of their high forward sensitivity, these arrays tend to produce a center-oriented soundstage.

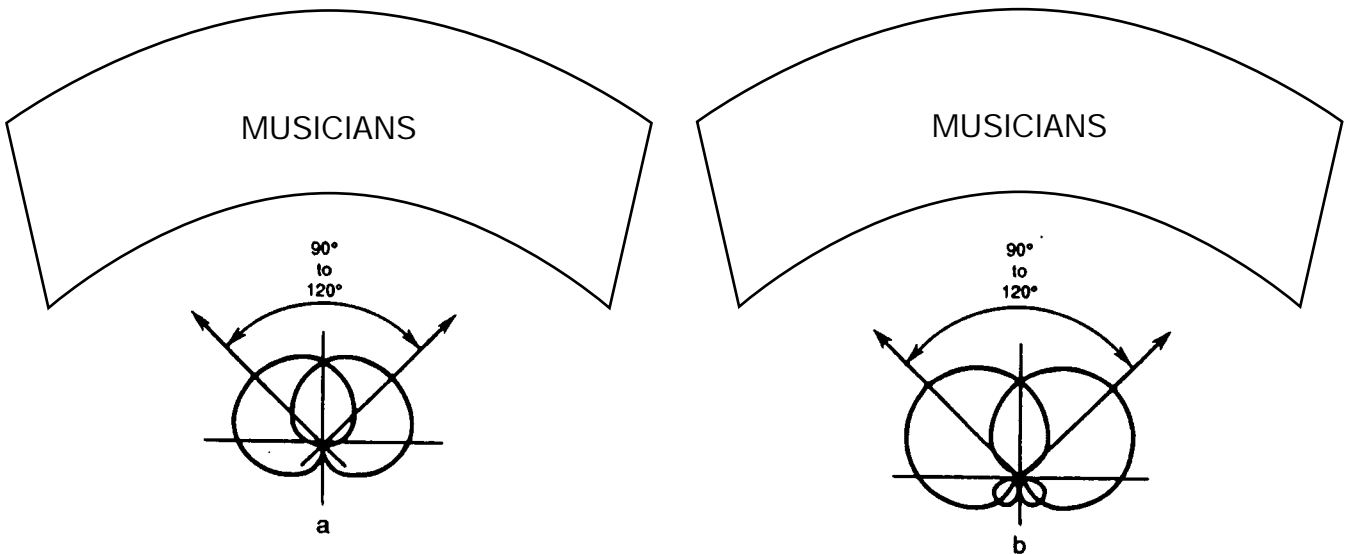

When possible, use the crossed hypercardioids with their splay angle upwards of 120° for greater spread. Do not hesitate to position musicians outside the nominal spread angle.

3. Near-Coincident Techniques

Departing slightly from coincident microphone usage, near-coincident techniques are very common. Here, a pair of microphones are spaced by a small distance, and their stereo separation enhanced by wide splay angles or by some kind of baffle between them. The so-called ORTF array is shown in Figure 13a. It uses a pair of cardioid microphones at a spacing of 17 cm (6.7 in) splayed at an angle of 110° . The effect of the separation is to add subtle arrival time cues for sound sources positioned at the sides. These work with the level differences produced by the splayed patterns to create a stereo soundstage that is both accurate and has a feeling of "air" about it.

Regarding microphone choice for ORTF application, small diaphragm cardioids such as the C480 are best, since their off-axis response is quite smooth and uncolored.

The baffle technique shown in Figure 13b is completely empirical and is shown here as an example of creative experimentation. The baffle has little effect at low frequencies, but enhances separation at higher frequencies. It may be used with either omni or directional microphones.

Figure 13

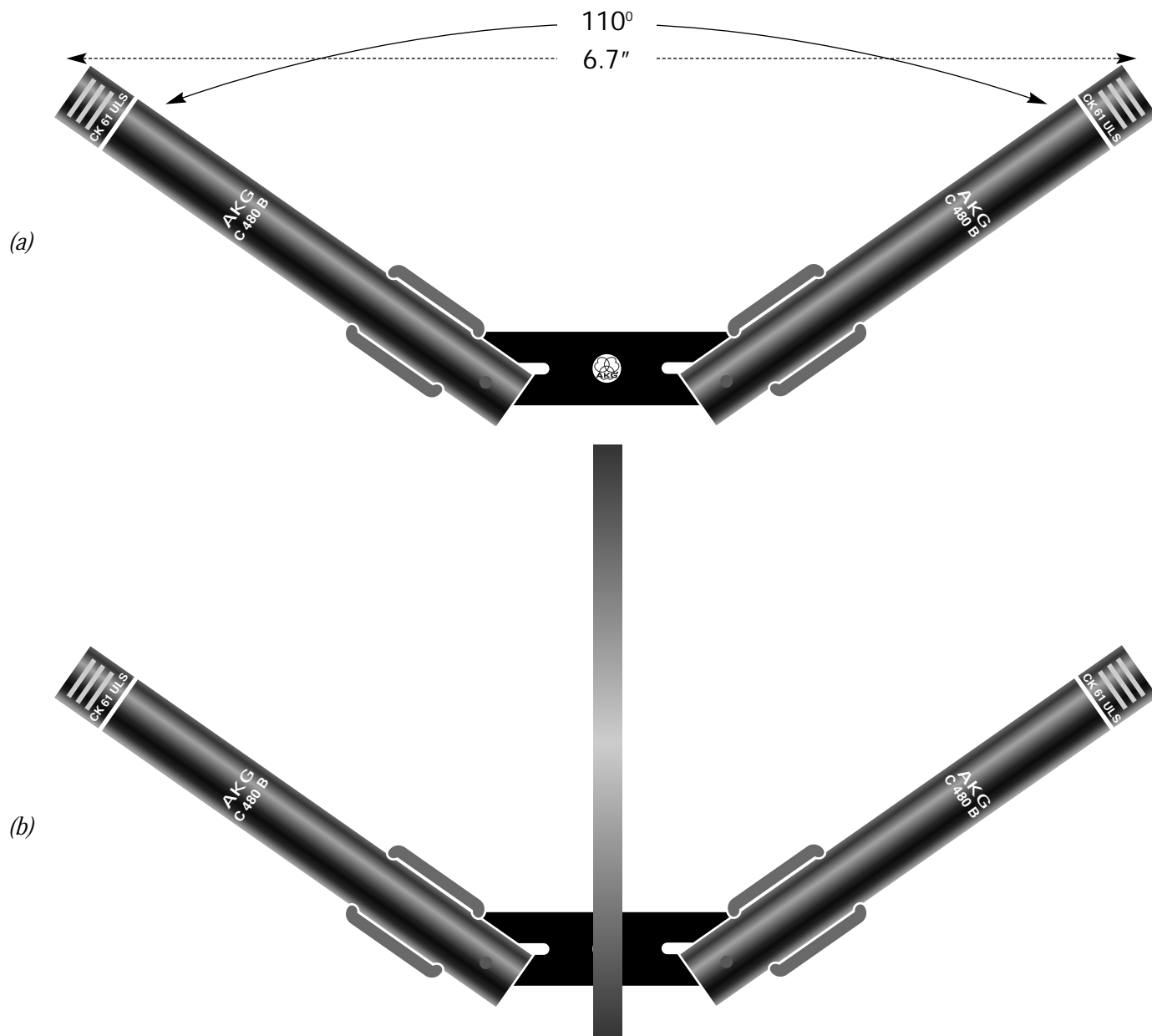

4. Spaced Omnidirectional Microphones (Omnis)

When stereo got underway commercially during the 1950s, spaced omnis were generally used (at least in the United States) for large scale orchestral pickup. Such a technique is shown in Figure 14. Distance A is normally about 1.5 meters (3 to 5 feet). The spacing B is about one-third the width of the performing ensemble. The microphones are normally about 3 meters (10 feet) above the floor.

Microphones L and R are panned respectively to left and right channels, while microphone C is panned equally between them. The technique often sacrifices image specificity for image spatiality. That is, precise imaging is downplayed for a larger feeling of acoustical space.

What to Listen For

The most difficult adjustment in recording with three spaced omnis is the level of the center microphone. If the recording is being recorded via three tracks, this critical decision can be deferred until later. However, if the recording is being made directly to two-channel stereo, then the critical level setting of the center microphone must be made carefully. A good loudspeaker monitoring setup is essential. Headphones can be very misleading in this situation. No more center microphone should be used than necessary to fill the "hole in the middle."

Summary of AKG microphones for spaced omni stereo:

CK62 Omni capsule with 480 preamplifier/power module. Provides the highest dynamic range possible. Blue Line series (SE300B with CK92) omnis may be used as well. Some engineers prefer large diameter omnis, but these models do not have as good an off-axis response as the smaller diameter models.

5. Combining the Above Techniques

Many engineers freely combine the techniques discussed above. Most popular here is the use of a pair of flanking omni microphones along with a center coincident or ORTF array, as shown in Figure 15. The coincident or near-coincident array provides the desired degree of image specificity, while the spaced omni flanking microphones provide a subtle highlighting of the acoustical space while giving slightly more width to the performing ensemble.

What to Listen For

As with three spaced omnis, the decisions to be made in direct-to-stereo recording are critical ones. We recommend that the engineer first listen only to the center pair of microphones, making sure that the soundstaging is basically correct. Any adjustments in microphone height or distance from the ensemble should be made. Then, the flanking omnis should be gradually brought into the mix. What you are listening for at this point is heightening the spatiality of the recording; mix in no more of the flanking microphones than necessary to accomplish this. Use the producer's ears to help you make the correct decision.

Spot Microphones

While we are combining techniques, it is often necessary to use spot microphones to bring out certain elements in a complex recording. For example, another ORTF or coincident pair above the woodwind section may be useful for bringing out certain musical lines. Other candidates for spot microphones include: harp, celesta, basses, and any other musical resource that may tend to get lost in the overall mix.

An important rule with spot microphones: pan them to the exact position where they appear on the stereo soundstage -- as monitored only over the main microphone pair!

Figure 14

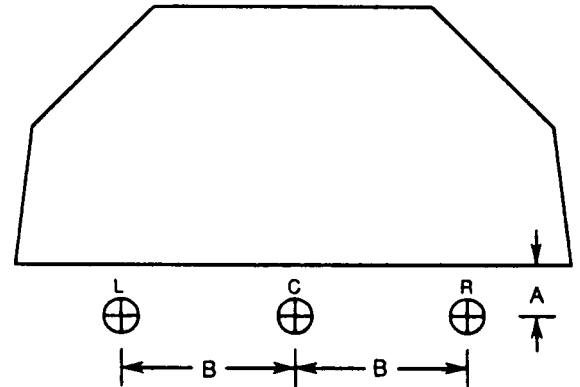
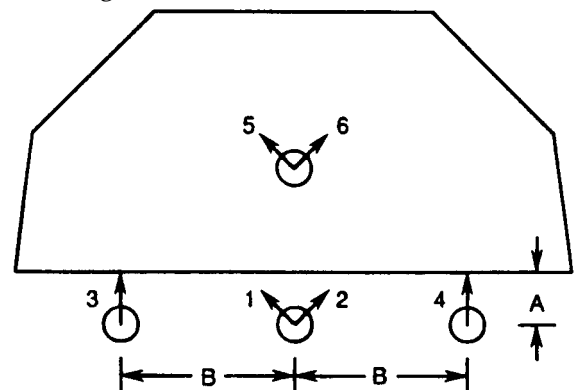

Figure 15



CONCLUSIONS

This manual has covered the major points of AKG microphone selection and usage in the modern recording studio and on the music reinforcement stage. This guide is only a beginning; recording engineers learn by continued listening and experimentation.

REFERENCES

1. Eargle, J., Handbook of Recording Engineering (1996) Chapman and Hall, New York.
2. Eargle, J., Music, Sound, and Technology (1995) Van Nostrand Reinhold, New York.

GLOSSARY:

A-B: A stereo microphone array consisting of a spaced pair of omni microphones. Normal spacing does not exceed about 1.5 meters (5 feet).

Bidirectional (Figure-8): A microphone pickup pattern that is maximum at zero and 180°, and minimum at plus and minus 90°. So named for the resemblance of the polar plot to the figure eight. (see attached summary of first-order cardioid microphones)

Cardioid: A microphone pickup pattern that is maximum at 0°, 6 dB down at plus and minus 90°, and effectively zero at 180°. So named for the resemblance of the polar plot to a heart shape. (see attached summary of first-order cardioid microphones)

Condenser (Capacitor) Microphone: A microphone that operates on the principle of a variable condenser or capacitor. The sound receptor is one plate of a capacitor that moves in sync with impinging sound waves; the resulting change in capacitance modulates an applied voltage on the capacitor.

Dynamic Microphone: A microphone that operates on the principle of voltage induction by a moving coil of wire in a magnetic field. The coil is attached to a light diaphragm that moves in sync with impinging sound waves.

Dynamic Range: The usable measured distance (measured in dB) between a mic's self noise and its peak level.

Hypercardioid: A microphone pickup pattern with high forward directivity. Response at plus and minus 90° is -12 dB, relative to on-axis. There is a minor lobe at 180° that is -6 dB relative to on-axis. (see attached summary of first-order cardioid microphones)

Image Specificity: The quality in a stereo recording that emphasizes precise positioning of a source on the stereo soundstage.

Image Spatiality: The quality in a stereo recording that emphasizes the acoustical space in which that recording was made.

Off-Axis Coloration: A characteristic of many directional microphones to exhibit erratic frequency response at angles other than the principal axis.

Omnidirectional: A microphone pickup pattern that is essentially equal in all directions. As a practical matter, most omni microphones will exhibit a preference along the principal axis at very high frequencies. (see attached summary of first-order cardioid microphones)

ORTF: Stands for Office of Radio-Television Française, the French national broadcasting company. Refers to a near-coincident stereo microphone pickup using two cardioids spaced by 6-3/4 inches and splayed at an angle of 110°.

Panning: Refers to the postproduction technique of mixing a signal in relative degrees between two stereo channels, causing the perceived stereo image position to be located at a specific point between the channels.

Polar Patterns: Refers to the typical measurement of microphone directivity in which microphone directional response is plotted with respect to bearing angle. (see attached summary of first-order cardioid microphones)

Presence Peak: Refers to the intentional increase in microphone sensitivity in the 2 to 4 kHz frequency range, useful for adding presence to vocal pickup.

Proximity Effect: Refers to the increase in low frequency response when directional microphones are used at short working distances. Caused by the pressure gradient at low frequencies between the primary and secondary openings to the microphone.

Signal to Noise Ratio: The difference between signal level at 1PA (94dB0) and the equivalent noise level of the microphone.

Stereo Soundstage: The virtual soundstage reproduced between a pair of loudspeakers by a two-channel stereo program source. Soundstage accuracy implies a continuity of images (reproduced sources) from left to right.

Supercardioid: A microphone pickup pattern that is mid-way between a cardioid and a hypercardioid. Response at plus and minus 90° is -8.6 dB relative to on-axis. Response at 180° is -11.7 dB relative to on-axis. (see attached summary of first order cardioid microphones)

Timbre: Refers to the sound quality of an instrument or other source of sound. From the French word meaning "stamp," or characteristic.

X-Y: Refers to any stereo pickup arrangement using a pair of directional microphones that are as closely spaced as possible.

SUMMARY OF FIRST-ORDER CARDIOID MICROPHONES

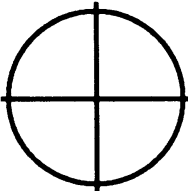
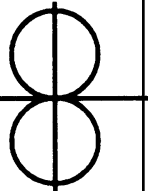
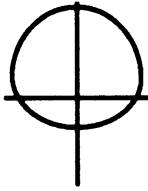
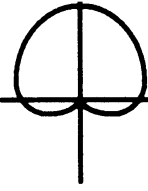
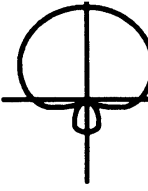
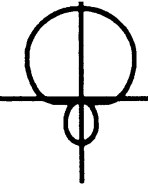
CHARACTERISTIC	OMNIDIRECTIONAL	BIDIRECTIONAL	SUBCARDIOID	CARDIOID	SUPERCARDIOID	HYPERCARDIOID
POLAR RESPONSE PATTERN						
POLAR EQUATION	1	$\text{Cos } \theta$	$.7 + .3\text{Cos } \theta$	$.5 + .5\text{Cos } \theta$	$.37 + .63\text{Cos } \theta$	$.25 + .75\text{Cos } \theta$
PICKUP ARC 3 dB DOWN	360°	90°	180°	131°	115°	105°
PICKUP ARC 6 dB DOWN	360°	120°	264°	180°	156°	141°
RELATIVE OUTPUT AT 90°(dB)	0	-∞	-3	-6	-8.6	-12
RELATIVE OUTPUT AT 180°(dB)	0	0	-8	-∞	-11.7	-6
ANGLE AT WHICH OUTPUT = ZERO	-	90°	-	180°	126°	110°
RANDOM ENERGY EFFICIENCY (REE)	1 0 dB	.333 -4.8 dB	.55 -2.5 dB	.333 -4.8 dB	.268 (1) -5.7 dB	.25 (2) -6 dB
DISTANCE FACTOR (DSF)	1	1.7	1.3	1.7	1.9	2

(1) MAXIMUM FRONT TO TOTAL RANDOM ENERGY EFFICIENCY FOR A FIRST-ORDER CARDIOID.

(2) MINIMUM RANDOM ENERGY EFFICIENCY FOR A FIRST-ORDER CARDIOID.



AKG Acoustics, U.S. • 1449 Donelson Pike • Nashville • TN 37217 • Tel: (615) 360-0499 • Fax: (615) 360-0275
Visit our Web Site at www.akgusa.com